

ENGINE

Model	Case 432T/M3 diesel*, Tier III certified
Type	4-stroke, turbocharged
Cylinders	4
Bore/Stroke	3.9 in x 4.1 in (99 mm x 104 mm)
Displacement	195 in ³ (3.2 L)
Fuel injection	Direct
Fuel	#2 Diesel
Fuel filter	In-line strainer
Air intake	Cross-flow
Cooling	Liquid
Engine speeds (rpm)	
High idle – no load	2675±75
Rated – full load	2500
Low idle	1075±75
Horsepower per SAE J1349	
Gross	74 (55 kW) @ 2500 rpm
Net	69 (52 kW) @ 2500 rpm
Peak torque	
@ 1400 rpm	203 lb-ft (275 N-m)

ENGINE COOLING

Radiator	
Core type	Square wave serpentine
Core size area	377 in ² (.243 m ²)
Rows of tubes	4
Cap pressure	14 psi (97 kPa)
Fan	
Diameter	18.9 in (480 mm)
Ratio	1.1:1
Water pump	
Style	Centrifugal
Flow	29 gpm (110 L/min)
Engine lubrication	
Pump	Deep sump with plate cooler and pressurized under-piston nozzles
Pump operating angle ratings	
Side-to-side	Rated 35°
Fore and aft	Rated 35°
Oil filtration	Replaceable, full-flow cartridge

POWERTRAIN

Drive pump	
Tandem, axial piston hydrostatic transmission with integral charge pump driven directly off engine flywheel	
Pump to engine ratio	1:1
Displacement	0 to 2.62 in ³ (43 cc)
Pump flow @ high idle engine rpm	30.3 gpm (115 L/min)
Flow	Bi-directional
Charge pressure	360 psi (24.8 bar)
System relief	4350 psi (300 bar)
Controls	Servo
Drive motors	Fixed displacement radial piston
Maximum displacement	28.7 in ³ (470 cc)
Speed @ high idle engine rpm	
@ max displacement	244 rpm
Optional high speed	407 rpm
Torque @ max displacement and relief pressure	1,655 lb-ft (2245 N-m)
Travel speed mph (km/h)	
Low range	7.2 (11.6)
High range (optional)	11.6 (18.7)
Final drive	Single-reduction chain drive
Drive chain	
Size	ASA #100HV
Tensile strength	32,180 lb (143 144 N)
Axles	
One-piece, forged induction-hardened high carbon steel	
Torque @ max displacement and relief pressure	4,633 lb-ft (6282 N-m)
Diameter	2.0 in (51 mm)
Length	14.6 in (371 mm)
Parking brakes	
Spring applied, hydraulic release disc	
Engagement	
Depress on/off brake button on handle or instrument panel, raise seat bar, get off seat, or stop engine	

HYDRAULIC SYSTEM

Standard equipment pump	
Type	Gear pump
Displacement	2.2 in ³ /rev (36 cc)
Pump flow @ rated engine rpm	
Total	23.8 gpm (90 L/min)
Optional high flow @ rated engine rpm	
Total	33.2 gpm (126 L/min)
Loader control valve	
3-spool open-center series with power beyond port	
Relief pressure	3050 psi (210 bar)
Port relief pressures	
Loader Raise	3120 psi (215 bar)
Bucket Dump	3800 psi (260 bar)
Bucket Curl	3350 psi (230 bar)
Hydraulic lines	
Tubing	37° JIC Flare
Loop hoses	SAE 100 R12
Hydraulic oil cooler	
Core type	Four row in-line
Hydraulic filter	
6 micron spin on replaceable element on the return line with warning indicator	

*Manufactured for Case by Iveco.

INSTRUMENTATION

Indicators

- Digital Hourmeter
- Fuel level LCD bar graph with alarm

Warning lights with alarms

- Engine coolant temperature
- Engine oil pressure
- Engine Malfunction
- Hydraulic charge pressure
- Hydraulic filter restriction
- Hydraulic oil temperature

Warning alarms

- Battery voltage (plus display)

Indicator light

- Engine preheat
- Parking brake
- Seat bar reminder

ELECTRICAL SYSTEM

Alternator 95 amp

Starter 2.7 kW

Battery

- 12-volt low-maintenance 1125 cold-cranking amps @ 0° F (-18° C)

OPERATOR ENVIRONMENT

ROPS/FOPS level 1 canopy w/side screens

Tilt ROPS/FOPS

Rear window w/ emergency escape

Instrument panels

Suspension vinyl seat

2 in (51 mm) retractable seat belt

Hand throttle

Foot throttle

Alarm package

Headliner

Top window

Cup holder

Power plug socket

Foot rest

Storage tray

Low effort ergonomic hand controls

Padded seat bar w/integral armrests

Loader control lockout system

Electric parking brake control

Floor cleanout panel

CYLINDERS

Lift cylinder

Bore diameter	2.5 in (63.5 mm)
Rod diameter	1.5 in (38.1 mm)
Stroke	35.8 in (910 mm)
Closed length	46.8 in (1190 mm)

Bucket cylinder

Bore diameter	2.75 in (69.9 mm)
Rod diameter	1.37 in (34.9 mm)
Stroke	14.6 in (370 mm)
Closed length	26.9 in (683 mm)

OPERATING WEIGHTS

Unit equipped with 10.00 x 16.5 Galaxy Beefy Baby II tires, 60 in (1.5 m) foundry/excavating bucket, mechanical attachment coupler, full fuel tank and 165 lb (75 kg) operator

	6605 lb (2996 kg)
Shipping weight	6055 lb (2747 kg)

Add-on weights

Side cab glass	+70 lb (32 kg)
Lexan® door	+50 lb (22.6 kg)
Glass door w/wiper	+77 lb (35 kg)
Suspension seat	+10 lb (4.5 kg)

SERVICE CAPACITIES

Fuel tank	22.0 gal (83.3 L)
Engine oil w/filter	9 qt (8.5 L)
Engine cooling system	12 qt (11.4 L)
Hydraulic system	
Reservoir	7.1 gal (26.8 L)
Total	13.2 gal (50 L)
Chain tanks (per side)	8 qt (7.6 L)

TIRE SELECTION

	Size	Ply Rating	Tread Depth	Tire Width	Width Over Tires	Tire Weight*
Galaxy XD2002	10.00 x 16.5	8	0.59 in (15 mm)	10.7 in (284 mm)	59 in (1.50 m)	52 lb (23.6 kg)
Galaxy XD2002	12.00 x 16.5	10	0.69 in (17 mm)	13.1 in (333 mm)	64 in (1.63 m)	72 lb (32.7 kg)
Galaxy Beefy Baby II	10.00 x 16.5	8	0.75 in (19 mm)	10.2 in (259 mm)	59 in (1.50 m)	61 lb (27.6 kg)
Galaxy Beefy Baby II	12.00 x 16.5	10	0.81 in (21 mm)	12.4 in (315 mm)	64 in (1.63 m)	82 lb (37.2 kg)
Galaxy Hulk	10.00 x 16.5	10	1.37 in (35 mm)	10.2 in (259 mm)	59 in (1.50 m)	79 lb (35.8 kg)
Galaxy Hippo	31.5 x 16.5	8	.75 in (19 mm)	12.8 in (325 mm)	64 in (1.63 m)	70 lb (31.7 kg)
Galaxy Solid Flex	10 x 16.5	n/a	.7 in (18 mm)	9.6 in (244 mm)	61 in (1.50 m)	230 lb (104 kg)
Galaxy Solid Flex (offset wheel)	10 x 16.5	n/a	.7 in (18 mm)	9.6 in (244 mm)	67 in (1.70 m)	230 lb (104 kg)

*Tire weight does not include the wheel weight.

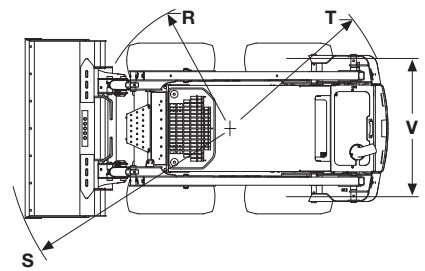
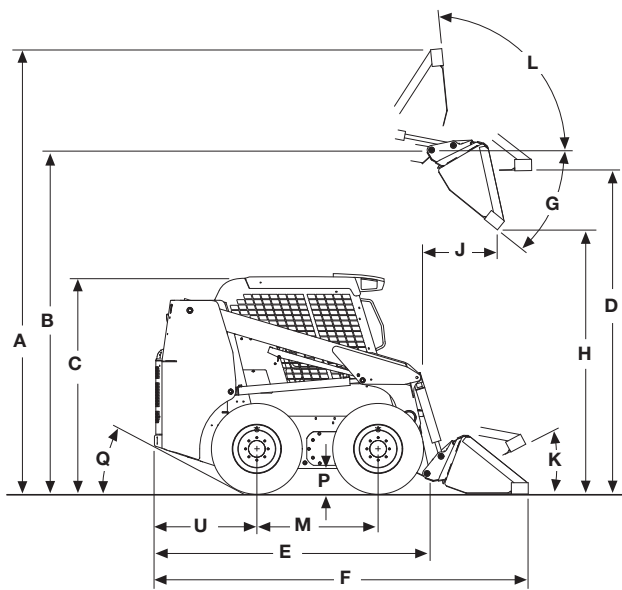

DIMENSIONS*

A. Overall operating height	
w/foundry/excavating bucket – short lip	151.6 in (3.85 m)
w/low profile bucket – standard lip	157.5 in (4.00 m)
w/low profile extended bucket – long lip	162.5 in (4.13 m)
Height to	
B. Bucket hinge pin	120.7 in (3.06 m)
C. Top of rollover protective structure	78.9 in (2.00 m)
D. Bottom of level bucket, loader arm fully raised	113.5 in (2.88 m)
Overall length	
E. w/o attachment w/coupler	102.5 in (2.60 m)
F. w/foundry/excavating bucket on ground	127.9 in (3.25 m)
F. w/low profile bucket on ground	132.9 in (3.38 m)
F. w/low profile extended bucket on ground	137.9 in (3.50 m)
G. Dump angle at maximum height	39°
H. Dump height – loader arm fully raised	
w/foundry/excavating bucket	96.1 in (2.44 m)
w/low profile bucket	92.6 in (2.35 m)
w/low profile extended bucket	89.4 in (2.27 m)
J. Dump reach – loader arm fully raised	
w/foundry/excavating bucket	22.9 in (0.58 m)
w/low profile bucket	28.8 in (0.73 m)
w/low profile extended bucket	32.6 in (0.83 m)
Maximum attachment rollback	
K. Bucket on ground	29°
L. Bucket at full height	96°
M. Wheelbase	42.3 in (1.07 m)
Ground clearance	
P. Bottom of belly pan	8.2 in (208 mm)
Q. Angle of departure	26°
Clearance circle front	
R. Less bucket	56.7 in (1.44 m)
S. w/60 in (1.52 m) foundry/excavating bucket on ground	76 in (1.93 m)
S. w/60 in (1.52 m) low profile bucket on ground	81.2 in (2.06 m)
S. w/60 in (1.52 m) low profile extended bucket on ground	85.9 in (2.18 m)
T. Clearance circle rear	59.2 in (1.50 m)
U. Rear axle to bumper	37.0 in (0.94 m)
V. Tread width, centerline to centerline	48.4 in (1.23 m)

NOTE: *Equipped with 10 x 16.5 Galaxy Beefy Baby II tires.

PERFORMANCE SPECS

Operating load	1850 lb (839 kg)
Tipping load	3700 lb (1678 kg)
Breakout force	
Lift cylinder	4,200 lbf (18 682 N)
Bucket cylinder	5500 lbf (24 465 N)
Dig depth	
w/bucket flat	0.2 in (6.00 mm)
Cycle time	
Raise	3.6 seconds
Lower	2.6 seconds
Dump	1.3 seconds
Rollback	1.6 seconds

NOTE: SAE rated lift capacities.

OPTIONAL BUCKETS

Type	Width inch (m)	Weight lb (kg)	Heaped Capacity ft ³ (m ³)
Foundry/ Excavating	60 (1.5)	270 (122)	11.5 (0.33)
	66 (1.6)	370 (168)	15.2 (0.43)
	72 (1.8)	390 (177)	16.7 (0.47)
	78 (2.0)	495 (225)	18.4 (0.52)
	84 (2.1)	597 (270)	21.9 (0.62)
Low Profile	60 (1.5)	360 (163)	11.5 (0.33)
	66 (1.6)	400 (181)	13.2 (0.37)
	72 (1.8)	425 (193)	14.5 (0.41)
	78 (2.0)	497 (225)	17.1 (0.48)
	84 (2.1)	597 (270)	21.9 (0.62)
Low Profile Extended	60 (1.5)	360 (163)	14.3 (0.40)
	66 (1.6)	434 (197)	15.5 (0.44)
	72 (1.8)	477 (216)	17.1 (0.48)
	78 (2.0)	502 (228)	18.6 (0.53)
	84 (2.1)	597 (270)	21.9 (0.62)
Utility/Light Material	60 (1.5)	350 (159)	19.7 (0.56)
	66 (1.6)	434 (197)	23.7 (0.67)
	72 (1.8)	497 (225)	27.9 (0.79)
	78 (2.0)	527 (239)	30.6 (0.87)
	84 (2.1)	597 (270)	35.3 (1.00)
Heavy-Duty/ Dirt	60 (1.5)	400 (181)	12.1 (0.34)
	66 (1.6)	474 (215)	13.3 (0.37)
	72 (1.8)	501 (227)	14.6 (0.41)
	78 (2.0)	527 (239)	15.9 (0.45)
	84 (2.1)	597 (270)	18.6 (0.53)

STANDARD EQUIPMENT

OPERATOR'S COMPARTMENT

ROPS/FOPS level 1 canopy w/side screens
Tilt ROPS/FOPS
Rear window w/emergency escape
Instrument panels
Suspension vinyl seat
2 in (51 mm) retractable seat belt
Hand throttle
Foot throttle
Alarm package
Headliner
Top window
Cup holder
Power plug socket
Foot rest
Storage tray
Low effort ergonomic hand controls
Padded seat bar w/integral armrests
Loader control lockout system
Electric parking brake control
Floor cleanout panel

LOADER

Radial loader arm design
Mechanical attachment coupler
Loader lift arm support strut

ENGINE

Case/Iveco 432T/M3 diesel
Tier III certified
No maintenance belt
Side-by-side radiator and oil cooler
Grid heater
Integral engine oil cooling
Fuel filter w/water trap
Dual element air cleaner
95 amp alternator
1125 CCA 12-volt battery

POWERTRAIN

Hydrostatic four wheel drive
Servo controlled pumps
ASA #100HS drive chain
SAHR disc parking brakes

HYDRAULICS

Auxiliary hydraulics 3050 psi
(210 bar) – 23.8 gpm (90 L/min)
Hydraulic circuit pedal lock
Loader arm-mounted ISO flat face connectors
Auxiliary function lockout override
Loader function lockout system
Loader lift lockout override
3-spool loader control valve
Heavy-duty oil cooler
Loader arm float position

OTHER

Integral bumper counterweight
Lockable service access hood
Single-point daily servicing
Halogen lights, 2-front, 2 side, 1-rear (halogen)
Rear tail lights
Remote oil drain

OPTIONAL EQUIPMENT

OPERATOR'S COMPARTMENT

Deluxe cloth suspension seat w/heater and lumbar support
Interior mirror
Electric auxiliary hydraulic control
Glass front door w/wiper & washer
Sliding side windows
3 inch retractable seat belt
Heater and AC
Radio
Demolition door

LOADER

Auxiliary front electric control
Ride control
Pilot controls
Hydraulic attachment coupler
Hydraulic one-way self-leveling

HYDRAULICS

High-flow auxiliary hydraulics
3050 psi (210 bar) – 33.2 gpm (126 L/min)
Second auxiliary hydraulics
Attachment case drain plumbing

ENGINE

Coolant block heater
Battery disconnect switch w/jumpstart terminals

OTHER

2 speed ground drive
Deluxe instrument panel
Road lights
Rotating beacon
Lift hooks
Special paint
Language decals
Factory-installed tires – see page 2
Buckets – see page 3
Bolt-on bucket cutting edges
42 in (1.07 m) and 48 in (1.22 m) pallet forks
Steel tracks
Lift cylinder guards

NOTE: All specifications are stated in accordance with SAE Standards or Recommended Practices, where applicable.

NOTE: All engines meet current EPA emissions requirements.

IMPORTANT: Case Construction Equipment Inc. reserves the right to change these specifications without notice and without incurring any obligation relating to such change. Case Construction Equipment Inc. does not warrant the safety or reliability of attachments from other manufacturers.

Case is a registered trademark of CNH America LLC. Any trademarks referred to herein, in association with goods and/or services of companies other than CNH America LLC, are the property of those respective companies.



www.casece.com