

# FOUNDATION ASSOCIATES ENGINEERING PTE LTD

5 Tuas Avenue 1 Singapore 639490

Tel: (65)6863 1633 Fax: (65)6863 1455

E-mail: [fnapl@singnet.com.sg](mailto:fnapl@singnet.com.sg)

Website: <http://www.fnapl.com>



## FAV EXCAVATOR MOUNTED HYDRAULIC VIBRATORY HAMMER (Self-Pick Type)



Excavator Mounted Hydraulic Vibratory Hammer is a machine widely used to drive and extract piles. With proper installation, the power and hydraulic pressure of the excavator can propel the vibratory hammer. The advantages of the FAV excavator mounted vibratory hammer are its small size and simple operation. It caters for different working environment for example; space restriction, drainage maintenance and marshland works. With the powerful functions and mobile characteristics, this excavator mounted hydraulic vibratory hammer can perform well under extreme conditions. The unique design also allows it to work very close to the construction sites with minimum effect to the environment and space constrain. In addition, it's low noise pollution and non- exhaust gas characteristics, using all well known parts to ensure reliability, FAV excavator mounted hydraulic vibratory hammer is the best option for contractors.

Item		FAV/SFV 250	FAV/SFV 300	FAV/SFV 350	FAV/SFV 450
Frequency (Max)	rpm	3,000	3,200	3,500	4,500
Weight	kg	1,500	2,200	2,800	3,500
Operating Pressure	bar	280	320	325	350
Vibratory Force	tons	20.5	35.6	45	60
Max. Pile Length	m	9	13	16	18
Suitable carrier	tons	18 - 25	30 - 40	40 - 50	40 - 65

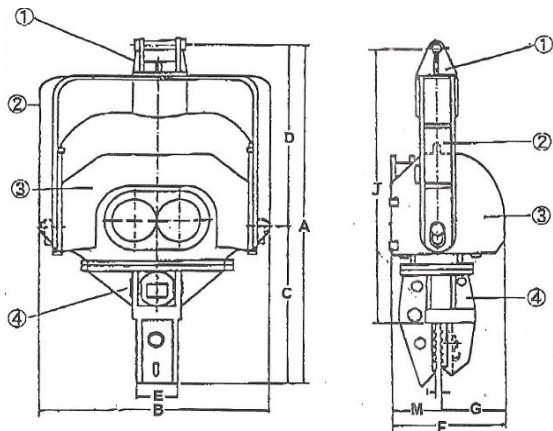

ITEM	FAV/SFV 250	FAV/SFV 300	FAV/SFV 350	FAV/SFV 450
A	1,800	2,150	2,350	2,600
B	1,250	1,400	1,570	1,650
C	850	1,050	1,100	120
D	950	1,100	1,300	140
E	215	215	215	215
F	600	710	730	910
G	250	280	300	350
H	350	430	450	500
I	50	50	50	50
J	1,420	1,790	1,860	2,050

Note: **Vibratory hammers applications are limited to soil condition of SPT35. Overloading Of the equipment will cause severe damages.**